

Sensors

Custom Mineral Insulated Thermocouples

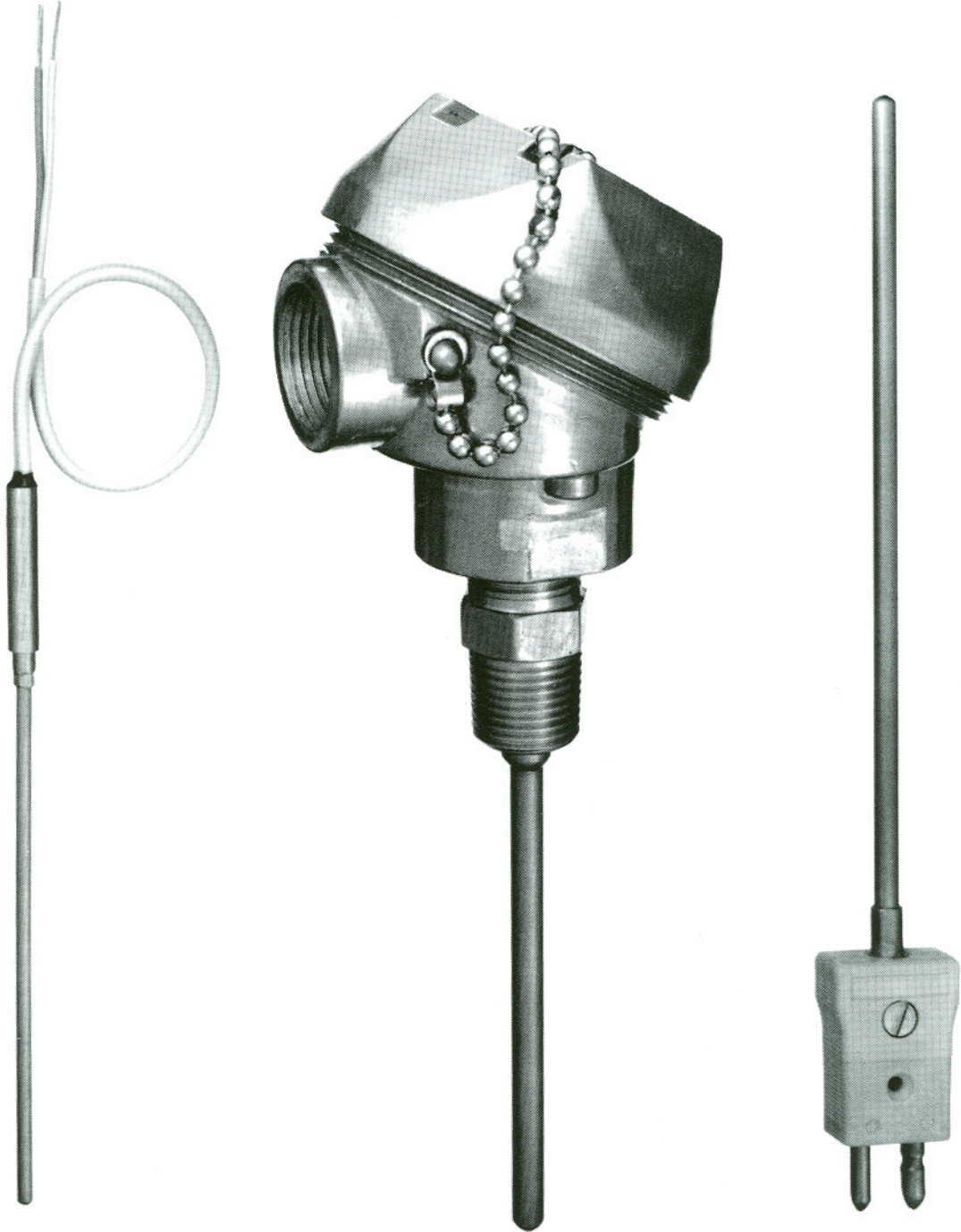

**PRECISION
MEASUREMENTS**

ISO 9002 Registered

Precision Measurements, Inc.
3715 Northcrest Road Suite #2
Atlanta, Georgia 30340
770-457-7099 FAX 770-458-5687

FORMPAK

Magnesium Oxide Insulation Metal Sheathed Thermocouple Wires

Easily Formed

Small size, fast response

Useful at high temperatures and pressures

FORMPACK Thermocouple assemblies consist of single, dual or triplex element thermocouple wires, hard packed magnesium oxide insulation, and a wide range of metal sheaths, in one compact unit. They offer the advantage of small size, fast response, and longer life than wire thermocouples.

These compacted thermocouple assemblies provide the answer for many special or difficult applications.

PRECISION MEASUREMENTS manufactures a complete thermocouple line including assemblies for chemical, power, primary metals and plastic industries.

Call one of our application engineers for assistance in selecting the custom thermocouple for your specific need.

Ordering Guide



Example Ordering Code:

Sheath Diameter	Thermocouple Element	Sheath Material	Measuring Junction	Immersion Range	Mounting Fitting	Cold-end Termination
125	J	304	I	6"	0	1B
Table #1	Table #2	Table #3	Table #4	Table #5	Table #6	Table #7

This simplified numbering system supplies detailed ordering information for any style mineral insulated thermocouple your application may require.

Table 1

Sheath Diameter

Sheath Diameter	Thermocouple Element	Sheath Material	Measuring Junction	Immersion Range	Mounting Fitting	Cold-end Termination
Table #1	Table #2	Table #3	Table #4	Table #5	Table #6	Table #7

For dual element construction insert a 2 before diameter code example: 2 - .250

Ordering Code	Diameter Inches	Conductor Size (Awg.)	Sheath Thickness (Inches)	Maximum Continuous Length (Feet)
.375	3/8	13	.053	65
.313	5/16	15	.044	100
.250	1/4	16	.035	140
.188	3/16	19	.026	260
.125	1/8	22	.018	500
.062	1/16	28	.009	1000
.040	1/25	32	.006	1000

Suggested Upper Temperature Limits for FORMPAK Thermocouples.

Calibration	1/25"	1/16"	1/8"	3/16"	1/4"	5/16"	3/8"
J	900°F	1000°F	1000°F	1200°F	1200°F	1200°F	1200°F
T	300°F	400°F	400°F	700°F	700°F	700°F	700°F
K	1400°F	1800°F	1800°F	2000°F	2000°F	2000°F	2100°F
E	800°F	1000°F	1000°F	1000°F	1100°F	1200°F	1300°F

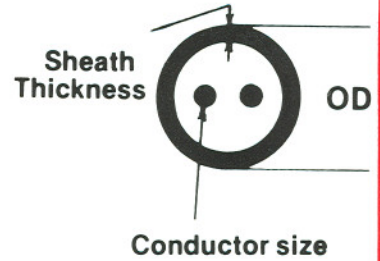

Thermocouple Element Calibration Table 2

Sheath Diameter	Thermocouple Element	Sheath Material	Measuring Junction	Immersion Range	Mounting Fitting	Cold-end Termination
Table #1	Table #2	Table #3	Table #4	Table #5	Table #6	Table #7

Limits of Error for Thermocouple Wire

Reference Junction 32°F (0°C)

Wire Alloys	Cal. Type	Temperature Range		Tolerance (whichever is greater)		
		°F	°C	Standard	Special	
ANSI Thermocouple Type						
* Iron (+) vs. Constantan (-)	J	32 to 1382°F	0 to 750°C	± 2.2°C or ± 0.75%	± 1.1°C or ± 0.4%	
Chromel™ (+) vs. Alumel™ (-)	K	32 to 2282°F	0 to 1250°C	± 2.2°C or ± 0.75%	± 1.1°C or ± 0.4%	
Chromel™ (+) vs. Constantan (-)	E	32 to 1652°F	0 to 900°C	± 1.7°C or ± 0.5%	± 1.0°C or ± 0.4%	
Copper (+) vs. Constantan (-)	T	32 to 662°F	0 to 350°C	± 1.0°C or ± 0.75%	± 0.5°C or ± 0.4%	
Platinum -13% Rhodium (+) vs. Platinum (-)	R	32 to 2642°F	0 to 1450°C	± 1.5°C or ± 0.25%	± 0.6°C or ± 0.1%	
Platinum -10% Rhodium (+) vs. Platinum (-)	S	32 to 2642°F	0 to 1450°C	± 1.5°C or ± 0.25%	± 0.6°C or ± 0.1%	
Platinum -30% Rhodium (+) vs. Platinum 6% Rhodium (-)	B	1598 to 3092°F	870 to 1700°C	± 0.5%	± 0.25%	
Nicrosil (+) vs. Nilil (-)	N	32 to 2282°F	0 to 1250°C	± 2.2°C or ± 0.75%	± 1.1°C or ± 0.4%	

* Magnetic ™Trade Mark Hoskins Mfg. Co.

Sheath Material Table 3

Sheath Diameter	Thermocouple Element	Sheath Material	Measuring Junction	Immersion Range	Mounting Fitting	Cold-end Termination
Table #1	Table #2	Table #3	Table #4	Table #5	Table #6	Table #7

Sheath Metal	Recommended Maximum Operating Temperature		Melting Temperature	
	°F	°C	°F	°C
Inconel 601	2100	1149	2494	1368
347 Stainless Steel	1650	899	2550	1399
316 Stainless Steel	1650	899	2500	1371
304 Stainless Steel	1650	899	2600	1427
446 Stainless Steel	2000	1093	2550	1399
310 Stainless Steel	2000	1093	2550	1399
316 L Stainless Steel	1650	899	2550	1399
Inconel 600	2100	1149	2600	1427
Hastelloy X	2300	1260	2350	1288
Nickel	2300	1260	2650	1454
Monel	1000	538	2370	1299
Platinum	3050	1677	3223	1773
Molybdenum *	4000	2200	4752	2622
Tantalum *	4500	2480	5425	2996

* For use in vacuum or inert atmosphere only

Measuring Junction Table 4

Sheath Diameter	Thermocouple Element	Sheath Material	Measuring Junction	Immersion Range	Mounting Fitting	Cold-end Termination
Table #1	Table #2	Table #3	Table #4	Table #5	Table #6	Table #7

Ordering Code

G Welded Grounded 

Most frequently requested, provides complete protection for measuring junction while insuring minimum response time.

I Insulated 

Ungrounded measuring junction is insulated from the sheath. Suggested for use on electrical apparatus or application where stray emf may influence temperature readings.

E Exposed junction 

Exposed junctions insure minimum response time not to be used where contaminating conditions exist

WPG Grounded junction with weld pad 

Available on 1/8" od and larger, pad dimensions are 1" x 1" x 1/8" material same as thermocouple type

WPI Insulated junction with weld pad

Immersion Range

Specify in inches as Illustrated Table 5

Sheath Diameter	Thermocouple Element	Sheath Material	Measuring Junction	Immersion Range	Mounting Fitting	Cold-end Termination
Table #1	Table #2	Table #3	Table #4	Table #5	Table #6	Table #7

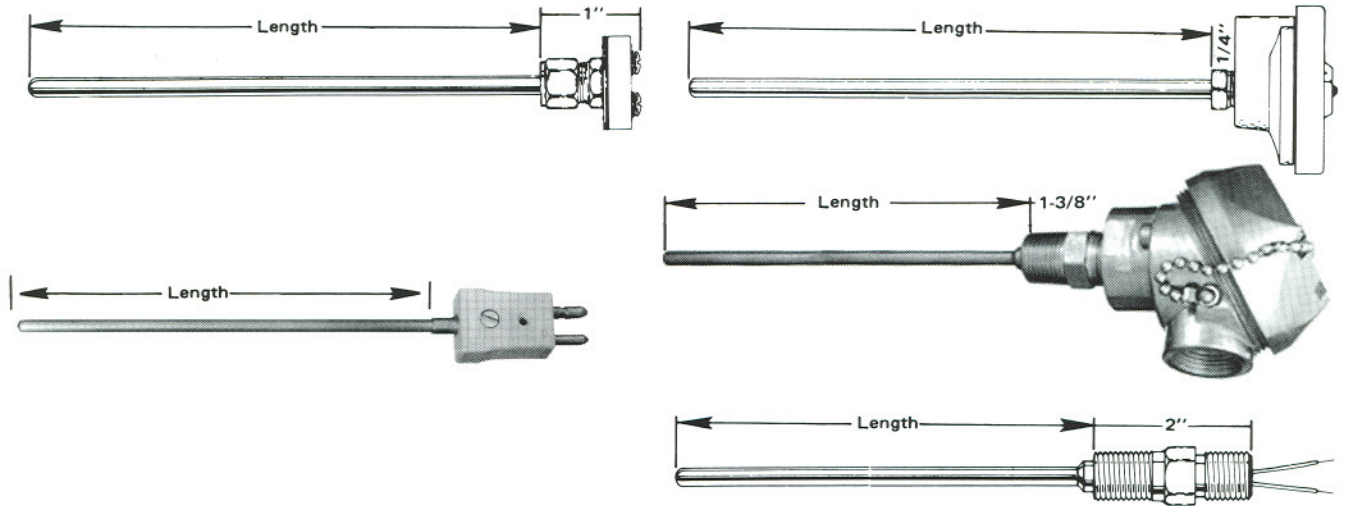

Mounting Fitting

Table 6

Sheath Diameter	Thermocouple Element	Sheath Material	Measuring Junction	Immersion Range	Mounting Fitting	Cold-end Termination
Table #1	Table #2	Table #3	Table #4	Table #5	Table #6	Table #7

Ordering Code

FB
FS



Fixed fitting brazed or welded to sheath for mounting thermocouple at a predetermined depth. Available in either brass or stainless steel. Specify NPT size when ordering. Example FB1/4"

AD



This adjustable compression fitting can be utilized at any point along the sheath. Available in either brass or stainless steel. NPT sizes of 1/8" or 1/4". Specify metal and thread size when ordering. Example: AD SS 1/4"

SL



Spring loaded adapters may be affixed to diameters 1/16, 1/8 & 3/16 inches

Termination

For thermocouples with leads specify type and length

Table 7

Sheath Diameter	Thermocouple Element	Sheath Material	Measuring Junction	Immersion Range	Mounting Fitting	Cold-end Termination
Table #1	Table #2	Table #3	Table #4	Table #5	Table #6	Table #7

Ordering Code Symbol & Length

- | | |
|---|--|
| 1 | No lead – specify connector type if required |
| 2 | #20 awg. stranded fiberglass insulated leads |
| 3 | #20 awg. stranded Polyvinyl insulated leads |
| 4 | #20 awg. stranded Teflon FEP insulated leads |
| 5 | Flexible armor tubing over fiberglass leads |
| 6 | Glass Duplex with Stainless Steel overbraid |
| 7 | Special – Description as specified |

Connector Terminations Ordering Codes

- A** 2" exposed ends
- B** Standard thermocouple plug 425°F
Add HT for high temperature 900°F
Add HD for solid pins
- C** Miniature thermocouple plug
- D** Dual element thermocouple plug
- E** General weatherproof head without process connection
- F** Miniature open terminal head
- G** Standard thermocouple jack
- H** Miniature lightweight head
- I** Miniature molded head
- J** Spade terminals (specify compensated or non compensated)
- K** General weatherproof head with 1/2" NPT process connection
specify KS for spring loaded fitting for use with thermowell

